

SIX CYLINDER ENGINE (Fig. 1)

INDEX

	Page		Page
Camshaft	15	Oil Filter	25
Camshaft Bearings	16	Oil Pan	22
Connecting Rods	19	Oil Pump	23
Crankshaft Main Bearings	20	Oversize and Undersize Engine Component	
Crankshaft Main Journals	20	Markings	75
Crankcase Ventilation System	71	Pistons, Pins and Rings	17
Cylinder Block	16	Rear Main Bearing Oil Seal	21
Cylinder Head	9	Repair of Damaged or Worn Threads	3
Engine Assembly	6	Rocker Arms and Shaft Assembly	8
Engine Performance	2	Special Service Tools	87
Installing Piston and Connecting Rod		Specifications	72
Assembly	19	Tappet	9
Measuring Connecting Rod Bearing		Timing Chain Cover, Oil Seal and Chain	14
Clearance	19	Valves and Valve Springs	11
Measuring Main Bearing Clearance	20	Valve Timing	14

SERVICE PROCEDURES

ENGINE ASSEMBLY

Removal

- (1) Scribe hood hinge outlines on hood and remove hood.
- (2) Drain cooling system and remove carburetor air cleaner.
- (3) Remove radiator and heater hoses and remove radiator.
- (4) Remove closed ventilation system and evaporation control system from cylinder head cover.
- (5) Disconnect fuel lines, carburetor linkage and wiring to engine.
- (6) Disconnect exhaust pipe at manifold.
- (7) Raise vehicle on a hoist.
- (8) Drain converter housing and transmission. Remove oil cooler lines, filler tube and linkage.
- (9) Remove clutch torque shaft and rods.
- (10) Remove speedometer cable and gear shift rods.
- (11) Disconnect propeller shaft and remove.
- (12) Install engine support fixture Tool C-3487A and leg C-3806 to support rear of engine.
- (13) Remove engine rear support crossmember (Figs. 2 or 3).
- (14) Remove transmission bolts from clutch housing.
- (15) Remove transmission.
- (16) Lower vehicle.
- (17) Install engine lifting fixture to cylinder head and attach a chain hoist to fixture eyebolt.
- (18) Remove engine support fixture.
- (19) Remove engine front mount bolts (Fig. 4).
- (20) Lift engine from engine compartment and install in engine repair stand.

Installation

- (1) Install engine lifting fixture and attach a chain hoist to fixture eyebolt.
- (2) Lower engine into engine compartment until front of engine is positioned on engine front mounts.
- (3) Install engine front mount bolts. **Do not tighten.**
- (4) Install engine support fixture Tool C-3487A and leg C-3806.
- (5) Remove chain hoist and engine lifting fixture.
- (6) Raise vehicle on a hoist.
- (7) Position rear of engine and install transmission.
- (8) Install crossmember to frame. Lower transmission to install engine rear support to extension and crossmember. Tighten to specifications as noted (Figs. 2 or 3).
- Remove engine support fixture.
- (9) Connect propeller shaft at transmission.
- (10) Install speedometer cable and gear shift rods.
- (11) Install clutch torque shaft, brake cables and rods.
- (12) Install cooler lines, and transmission filler tube.
- (13) Lower vehicle.
- (14) Tighten engine front mount bolts to specified torque (Fig. 4).
- (15) Connect exhaust pipe at the manifold using a new gasket.
- (16) Connect fuel lines, carburetor linkage and wiring to engine.
- (17) Install closed ventilation system and evaporation control system on cylinder head cover.
- (18) Install hood using scribe marks for proper alignment.
- (19) Close all drain cocks and fill cooling system.

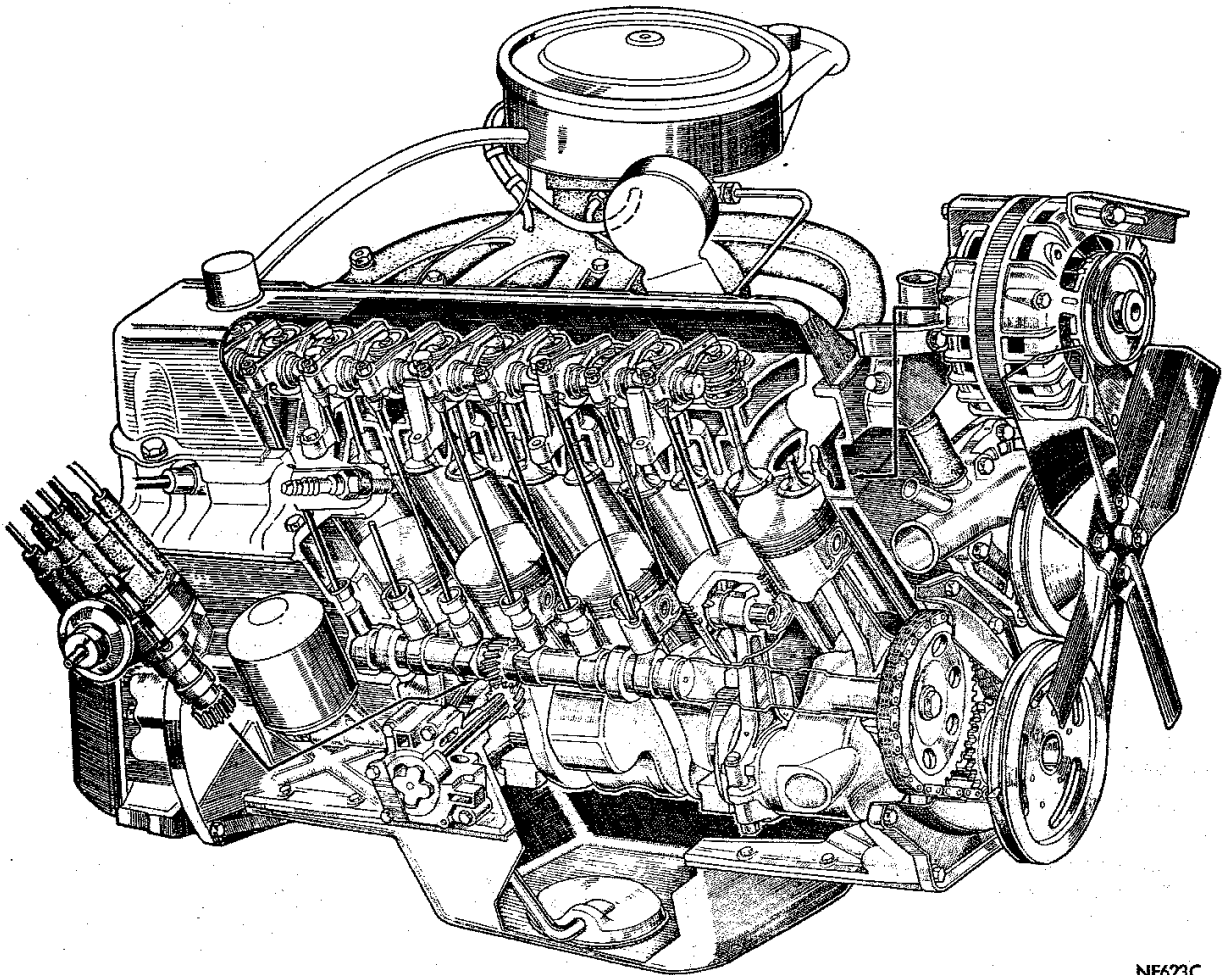

Fig. 1—Six Cylinder Engine Cutaway View

NF623C

(20) Fill engine crankcase and transmission. Refer to "Lubrication" Group O, for quantities and lubricants to use. Inspect entire system for leaks and correct.

(21) Start engine and run until normal temperature is reached.

(22) Inspect timing (with vacuum advance line removed), adjust carburetor and transmission linkage as necessary. Connect vacuum line and road test vehicle.

Engine Removal Without Removing Automatic Transmission

(1) Scribe hood hinge outlines on hood and remove hood.

(2) Drain cooling system and remove carburetor air cleaner.

(3) Remove radiator and heater hoses and remove radiator. Set fan shroud aside.

(4) Air Conditioning if so equipped see general information.

(5) Remove vacuum lines, distributor cap and wiring.

(6) Remove carburetor, linkage, starter wires and oil pressure wire.

(7) Remove power steering hoses if so equipped.

(8) Remove starter motor, alternator, charcoal canister and horns.

(9) Remove exhaust pipe at manifold.

(10) Remove bell housing bolts and inspection plate.

(11) Remove torque converter drive plate bolts from torque converter drive plate. Mark converter and drive plate to aid in reassembly.

(12) Support transmission with transmission stand tool number C-3201-A in its normal position relative to the vehicle. This will assure that the torque converter will remain in proper position in the transmission housing.

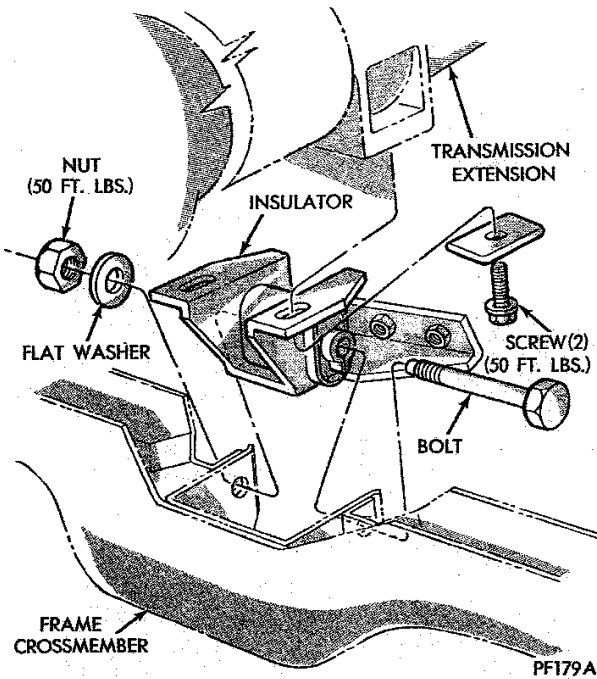

Fig. 2—Engine Rear Mount H,N,F and G

- (13) Disconnect the engine from the torque converter drive plate.
- (14) Install engine lifting fixture. Attach a chain hoist to fixture eyebolt.
- (15) Remove engine front mount bolts.
- (16) Remove engine from engine compartment and install in engine repair stand.

Installation

- (1) Remove engine from repair stand and install in engine compartment.
- (2) Install torque converter drive plate bolts and front end mounts.
- (3) Install bell housing bolts and inspection plate. Remove stand from transmission.
- (4) Remove engine lifting fixture and install carburetor and lines.
- (5) Install starter motor, alternator, charcoal canister and lines.
- (6) Install vacuum lines, distributor cap and wiring.
- (7) Connect exhaust pipe at manifold using new gasket.
- (8) Connect carburetor linkage and wiring to engine.
- (9) Install radiator, radiator hoses and heater hoses.
- (10) Set fan shroud in position. Fill cooling system full.
- (11) Install carburetor air cleaner. Connect vacuum hose, power steering hoses, if so equipped.
- (12) For emission controls see Emission Control

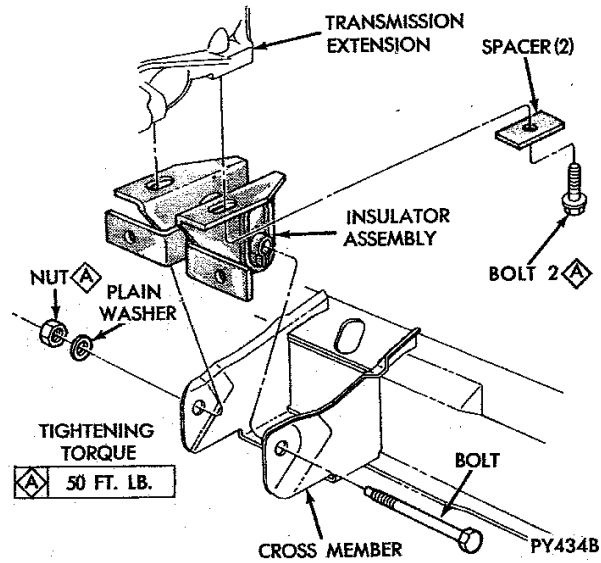

Fig. 3—Engine Rear Mount X,S,R and W

Systems Group 25 for service procedures.

- (13) Install air conditioning equipment if so equipped.
- (14) Warm engine and adjust.
- (15) Install hood and line up.
- (16) Road test vehicle.

ROCKER ARMS AND SHAFT ASSEMBLY

Stamped steel rocker arms are arranged on a single rocker arm shaft. Hardened steel spacers are used between the pairs of rocker arms. The rocker shaft is held in place by bolts and stamped steel retainers attached to the seven brackets on the cylinder head.

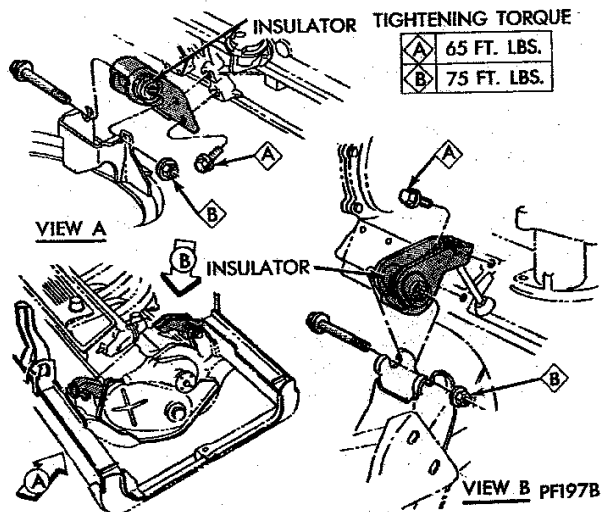

Fig. 4—Engine Front Mounts (225) H,N,F,G,R and W